

T87 STATIC PIPEBURSTER

SPECIFICATIONS & DATA SHEET

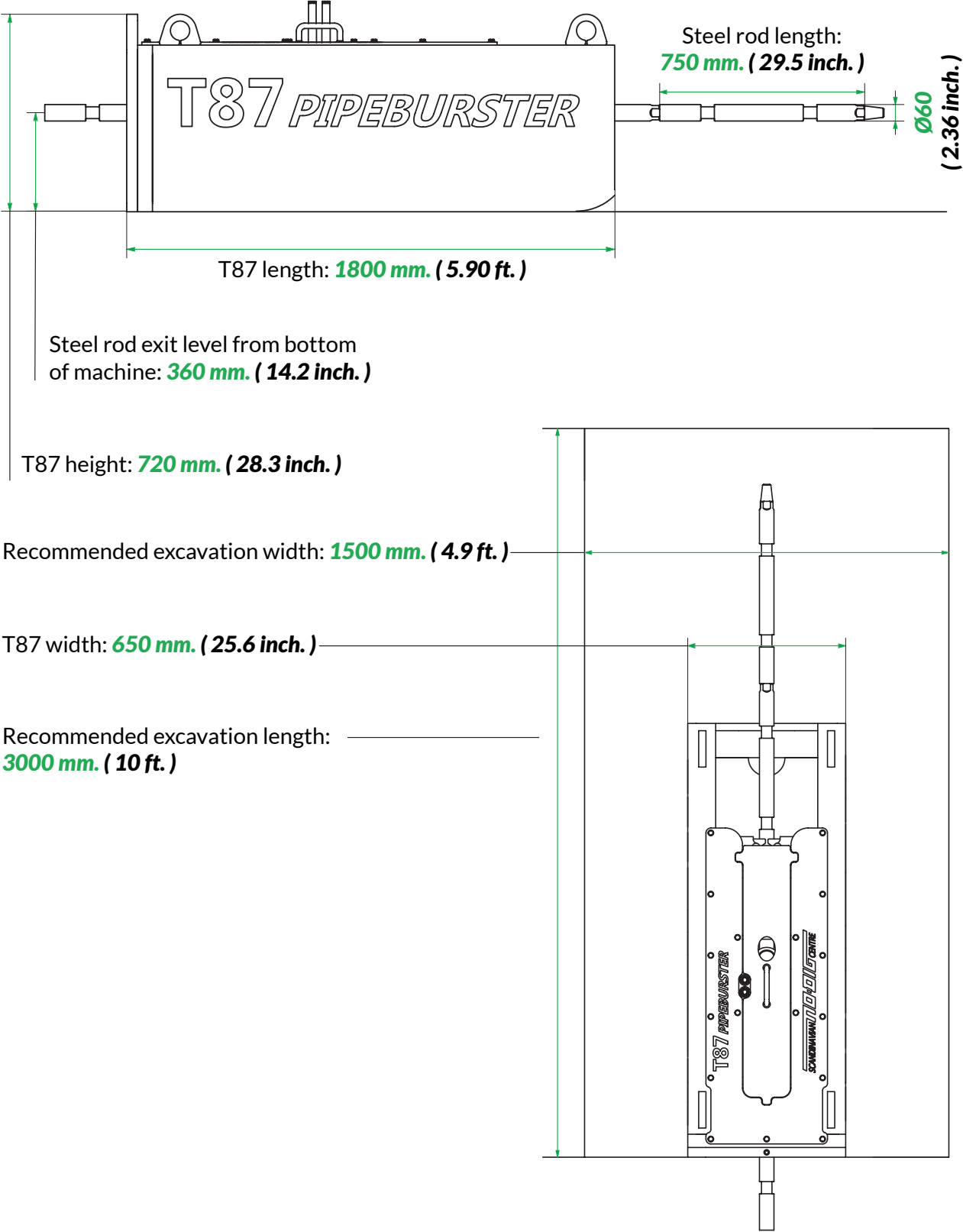



Specifications	Pulling unit	Power pack	Steel rods
Pulling force	92 metric tons (202825 lbs.)		
Measurements	180 x 65 x 72 cm. (71 x 25.6 x 28.3 inch.)	120 x 110 x 120 cm. (47.2 x 43.3 x 47.2 inch.)	Std. Ø60 mm. x 0.75 meter. (2.36 x 29.5 inch.)
Weight	1400 kg. (3086 lbs.)	820 kg. (1807 lbs.)	Ø60 mm. steel rod: 15 kg. (33 lbs.)
Engine		Kubota 3-cyl. diesel 22 bhp. / 16,40 kW. Fuel cap. 35 ltr. (9.25 gal.) Fuel consumption: 5 ltr. / hr. (1.3 gal. / hr.)	
Hydraulic system	3 cylinders	Max. 250 bar / 3625 psi. Pump 1: 35.0 ltr. / min (9.25 gal. / min.) Pump 2: 22.5 ltr. / min (5.95 gal. / min.) Variable pump speed: < 70 bar. (1015 psi.) → 57.5 ltr. (15.2 gal.) / min. < 70 bar. (1015 psi.) → 22.5 ltr. (5.95 gal.) / min. Hydraulic oil cap: 85 ltr. (22.45 gal.)	
Operational speed	Up to 2.0 meter. / min. (6.5 ft. / min.)		
Operational range, Existing pipe diameter	Ø70 mm. → Ø450 mm. (3 → 16 inch.)		